

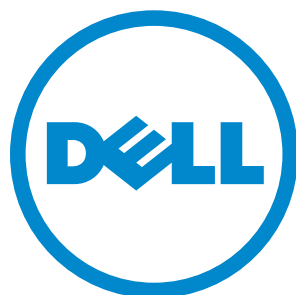

Installing and Maintaining the C300 System



Notes, Cautions, and Warnings

 **NOTE:** A NOTE indicates important information that helps you make better use of your computer.

 **CAUTION:** A CAUTION indicates potential damage to hardware or loss of data if instructions are not followed.

 **WARNING:** A WARNING indicates a potential for property damage, personal injury, or death.

Information in this publication is subject to change without notice.

© 2013 Dell Networking. All rights reserved.

Reproduction of these materials in any manner whatsoever without the written permission of Dell Inc. is strictly forbidden.

Trademarks used in this text: Dell™, the DELL logo, Dell Precision™, OptiPlex™, Latitude™, PowerEdge™, PowerVault™, PowerConnect™, OpenManage™, EqualLogic™, KACE™, FlexAddress™ and Vostro™ are trademarks of Dell Inc. Intel®, Pentium®, Xeon®, Core™ and Celeron® are registered trademarks of Intel Corporation in the U.S. and other countries. AMD® is a registered trademark and AMD Opteron™, AMD Phenom™, and AMD Sempron™ are trademarks of Advanced Micro Devices, Inc. Microsoft®, Windows®, Windows Server®, MS-DOS® and Windows Vista® are either trademarks or registered trademarks of Microsoft Corporation in the United States and/or other countries. Red Hat Enterprise Linux® and Enterprise Linux® are registered trademarks of Red Hat, Inc. in the United States and/or other countries. Novell® is a registered trademark and SUSE™ is a trademark of Novell Inc. in the United States and other countries. Oracle® is a registered trademark of Oracle Corporation and/or its affiliates. Citrix®, Xen®, XenServer® and XenMotion® are either registered trademarks or trademarks of Citrix Systems, Inc. in the United States and/or other countries. VMware®, Virtual SMP®, vMotion®, vCenter®, and vSphere® are registered trademarks or trademarks of VMWare, Inc. in the United States or other countries.

Other trademarks and trade names may be used in this publication to refer to either the entities claiming the marks and names or their products. Dell Inc. disclaims any proprietary interest in trademarks and trade names other than its own.

Contents

- 1 About this Guide
 - Information Symbols and Warnings 7
 - Related Documents. 9

- 2 Overview
 - C300 System Installation Process 12

- 3 Preparing the Site
 - Site Selection Criteria 13
 - Rack Mounting 14
 - Requirements 14
 - Shipping and Storing Components 15

- 4 Installing C300 Fan Tray
 - Removing the Fan Tray. 18
 - Fan Speed 18

- 5 Installing RPMs and Line Cards
 - Route Processor Modules. 19
 - RPM Label and LEDs 19
 - Line Cards. 20
 - Blank Panels 20
 - Installing the RPMs and Line Cards 20

- 6 RPM Cables
 - Connecting the Console Port 25
 - Cable and Adapter Pin Assignments 25
 - Accessing the Console with a DB-9 Adapter 26
 - Accessing the Console with a DB-25 Adapter 26

- 7 Installing AC Power Supplies
 - Installing the AC Power Supply. 32
 - Power Cord Requirements. 32
 - Power Over Ethernet (PoE) 32
 - Power Over Ethernet Plus (PoE+) 33

8	Installing DC Power Entry Modules	
	Recommended Normal Operating Conditions	35
	Redundancy	35
	Cable and Connector Requirements.	35
	Installing a DC PEM	36
	Status LED	39
	Removing a DC PEM	39
9	Powering Up	
	Supplying	42
	Booting from the BOOT_USER Prompt	43
10	Removing and Replacing Components	
	Removing and Replacing the Fan Tray.	45
	Removing and Replacing Power Supply Units	46
	Removing and Replacing a Line Card	47
11	Installing the Chassis	
	Safety Considerations	51
	Installing the Chassis into an Equipment Rack.	51
12	System Boot	
	Booting from the BOOT_USER Prompt	55
13	The Compact Flash Card	
	Inserting the Compact Flash Card	59
	Removing the Compact Flash Card	59
	Formatting the Compact Flash Card.	60
A	Alarms	
	AC Supplies and Alarms	62
B	System Specifications	
	Physical Design.	63
	Chassis Dimensions	63
	Component Dimensions	64
	System Specifications	64
	Component Power Requirements	65
	Agency Compliance.	66
	Safety Standards and Compliance Agency Certifications.	67

Electromagnetic Compatibility (EMC)	68
Product Recycling and Disposal	68
C Contacting Technical Support	
The iSupport Website	71
Accessing iSupport Services	71
Contacting the Technical Assistance Center	71
Locating Serial Numbers	72
Requesting a Hardware Replacement	72

About this Guide

This guide provides site preparation recommendations and instructions for installing the Dell Networking C300 chassis, fan tray, power supply units (supplies), route processor modules (RPMs), and line cards.



The C300 system is packaged with all of the necessary components, including slot blanks for RPMs, power supplies, and line cards.

Information Symbols and Warnings

The following graphic symbols are used in this document to bring attention to hazards that exist when handling the C300 and its components. Please read these alerts and heed their warnings and cautions.

[Table 1-1](#) describes symbols contained in this guide.

Table 1-1. Information Symbols

Symbol	Warning	Description
	Note	This symbol informs you of important operational information.
	Caution	This symbol informs you that improper handling and installation could result in equipment damage or loss of data.
	Warning	This symbol signals information about hardware handling that could result in injury.

 **WARNING:** The installation of this equipment shall be performed by trained and qualified personnel only. Read this guide before installing and powering up this equipment. This equipment contains two AC- cords. Disconnect both cords before servicing.

















 **WARNING:** Class 1 laser product.

 **ATTENTION:** Produit laser de classe 1

 **WARNUNG:** Laserprodukt der Klasse 1



 **WARNING:** This equipment contains optical transceivers, which comply with the limits of Class 1 laser radiation. Visible and invisible laser radiation may be emitted from the aperture of the optical transceiver ports when no cable is connected. Avoid exposure to laser radiation and do not stare into open apertures.

-  **WARNING:** Building Supply Notice for AC Supply Use. This product relies on the building's installation for short-circuit (overcurrent) protection. Ensure that a fuse or circuit breaker no larger than 120 VAC, 15A U.S. (240 VAC, 10A international) is used on the phase conductors (all current-carrying conductors).
-  **ATTENTION:** Pour ce qui est de la protection contre les courts-circuits (surtension), ce produit dépend de l'installation électrique du local. Vérifier qu'un fusible ou qu'un disjoncteur de 120 V alt., 15 A U.S. maximum (240 V alt., 10 A international) est utilisé sur les conducteurs de phase (conducteurs de charge).
-  **WARNUNG:** Dieses Produkt ist darauf angewiesen, daß im Gebäude ein Kurzschluß- bzw. Überstromschutz installiert ist. Stellen Sie sicher, daß eine Sicherung oder ein Unterbrecher von nicht mehr als 240 V Wechselstrom, 10 A (bzw. in den USA 120 V Wechselstrom, 15 A) an den Phasenleitern (allen stromführenden Leitern) verwendet wird.
-  **WARNING:** Building Supply Notice for DC Supply Use: An external disconnect must be provided and be easily accessible. Dell Networking recommends the use of a 60A circuit breaker.
-  **ATTENTION:** Un interrupteur externe doit être fournis et doit être facilement accessible. Dell Networking recommande l'utilisation d'un disjoncteur de 60Ampères.
-  **WARNUNG:** Eine leicht zugängliche Trennvorrichtung muss in der Verdrahtung eingebaut sein. Dell Networking empfiehlt einen 60A Sicherungsautomaten zu benutzen.
-  **CAUTION:** Earthing (AKA grounding) connection essential before connecting supply. Always make the ground connection first and disconnect it last.
-  **CAUTION:** Wear grounding wrist straps when handling this equipment to avoid ESD damage.
-  **CAUTION:** Disposal of this equipment should be handled according to all national laws and regulations. See [Product Recycling and Disposal](#)
-  **CAUTION:** This unit has more than one power supply connection; all connections must be removed to remove all power from the unit.
-  **ATTENTION:** Cette unité est équipée de plusieurs raccordements d'alimentation. Pour supprimer tout courant électrique de l'unité, tous les cordons d'alimentation doivent être débranchés.
-  **WARNUNG:** Diese Einheit verfügt über mehr als einen Stromanschluß; um Strom gänzlich von der Einheit fernzuhalten, müssen alle Stromzufuhren abgetrennt sein.
-  **CAUTION:** Lithium Battery Notice: Danger of explosion if battery is replaced with incorrect type. Replace only with the same type recommended by the manufacturer. Dispose of used batteries according to the manufacturer's instructions.
-  **ACHTUNG:** Explosionsgefahr wenn die Battery in umgekehrter Polarität eingesetzt wird. Nur mit einem gleichen oder ähnlichen, vom Hersteller empfohlenen Typ, ersetzen. Verbrauchte Batterien müssen per den Instructionen des Herstellers verwertet werden.
-  **ATTENTION:** Il y a danger d'explosion s'il a remplacement incorrect de la batterie. Remplacer uniquement avec une batterie du meme type ou d'un type equivalent recommande par le constructeur. Mettre au rebut les batteries usages conformement aux instructions du fabricant.
-  **WARNING:** Leakage Current (High Touch Current) in AC-powered systems with more than 3+1 power supplies. The power cord plugs must be secured to the building outlets by the qualified chassis installer or a qualified electrician.
-  **NOTE:** Other cautionary statements appear in context elsewhere in this book.

Related Documents

For more information about the C300 system, refer to the following documents:

- *FTOS Command Reference for C-Series*
- *FTOS Configuration Guide for C-Series*

Overview

The C300 is a high performance switch/router. The 10-slot system contains two slots for Route Processor Modules (RPMs) and eight slots for line cards.

Figure 2-1. C300 Chassis (Front View)

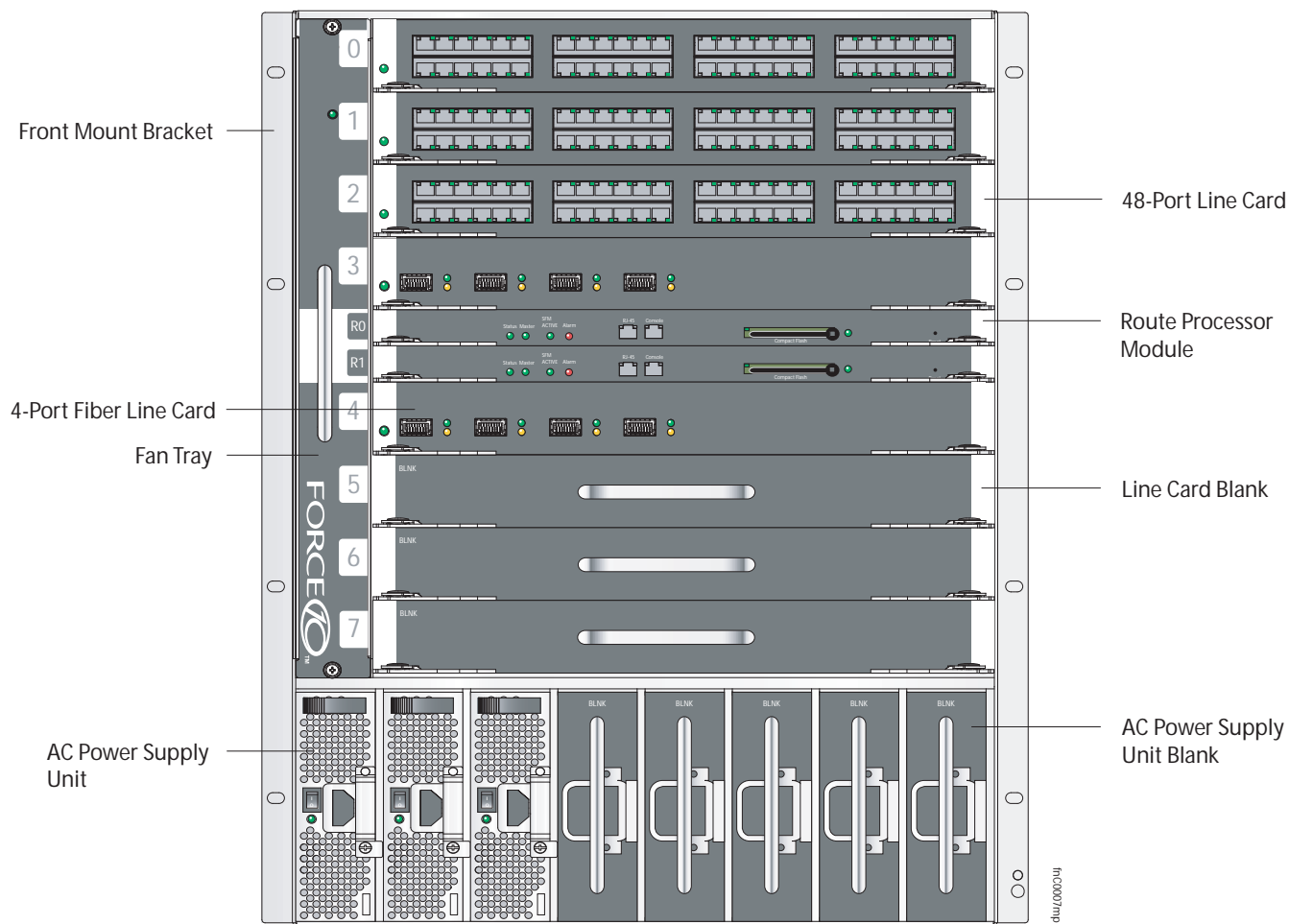

Table 2-1. C300 Component Requirements

Component	Minimum	Maximum	Field-Replaceable
Backplane (factory installed)	1	1	No
Fan tray	1	1	Yes
RPM	1	2	Yes
Line card	1	8	Yes
AC Power Supply	1	8	Yes

C300 System Installation Process

The Dell Networking recommended installation process is described below.

Step	Task	Relevant Section in the Manual
1	Prepare the site.	Site Selection Criteria
2	Unpack the chassis and components.	Shipping and Storing Components
3	Install the chassis in a rack.	Installing the Chassis into an Equipment Rack
4	Install the fan tray.	Installing C300 Fan Tray
5	Install the RPMs and line cards.	Installing RPMs and Line Cards
6	Connect console and management cables.	RPM Cables
7	Install the power supplies.	Installing AC Power Supplies
8	Switch on all of the power supplies.	Powering Up

Preparing the Site

Site Selection Criteria

Before beginning the installation process, make sure that the area where you intend to install your C300 meets the following safety requirements:

- It is in a restricted access area.
- It is in a dry, clean, well-ventilated, temperature-controlled room, that is away from heat sources such as hot air vents or direct sunlight.
- It is away from sources of severe electromagnetic noise.
- Power supply is adequate for power requirements.
 - Connect the C300 System to the appropriate branch circuit protection as defined by local electrical codes.

 **WARNING:** The C300 does not have a main disconnect device installed. It is the responsibility of the installer to provide a suitable disconnecting device in the building installation and ensure that it is located/installed near the equipment and is easily accessible.

- It is positioned in a rack with adequate space in the front, rear, and sides of the unit for proper ventilation, access to cables, and maintenance access.
 - Allow *at least* six inches (16 cm) of clearance around the side intake and exhaust vents.
 - Allow *at least* 12 inches (30.5 cm) between two C300s or an C300 and another side airflow chassis.
 - Allow *at least* 18 inches in the front and 20 inches in the rear of the rack.

 **NOTE:** The C-Series does not have an air filter, so take special care in making sure that the installation site and the chassis itself are cleaned regularly.

Rack Mounting

When you prepare your equipment rack:

- Make sure that the rack is bolted to the floor and braced to a wall or ceiling.
- Make sure that the rack is permanently grounded to earth ground. The equipment rack must be grounded to the same ground point used by the service in your area.
- The AC cord is the primary ground.

When you install the chassis, use a level to ensure the chassis is installed level.

Requirements

There are two types of power supplies: Power Supply 1200W-AC and Power Supply 1600W-AC. The minimum and the redundant power supplies required to operate is listed in the table below. Dell Networking recommends the redundancy configuration.

	Voltage	Minimum PSUs	Minimum with Redundant PSUs
Power Supply 1200W-AC/Power Supply 1600W-AC	100-120	2	3
Power Supply 1200W-AC	200-240	2	3
Power Supply 1600W-AC	200-240	1	2

The C300 requirements are given below:

Table 3-1. System Specifications

Parameter	Specifications
Nominal Input Voltage	100 - 240 VAC 50/60 Hz
Maximum AC Power Supply Input Current (Based on 1200 W output for 100/120 V and 1600 W 200/240 V lines)	14 A @ 100 V per AC Power Supply 11 A @ 120 VAC per AC Power Supply 9 A @ 200 VAC per AC Power Supply 7 A @ 240 VAC per AC Power Supply
Maximum System Power Input	9,667 KVA @ 100/120 V 12,596 KVA @ 200/240 V
Maximum Thermal Output at 100/120V	9,235 BTU/hour
Maximum Thermal Output at 200/240V	9,299 BTU/hour

Shipping and Storing Components

 **CAUTION:** Do not transport a C300 chassis with the components (line cards, supplies, and RPMs) installed in the chassis. Place the components in their original protective shipping packaging and original shipping position. Shipping components installed in the chassis or without their protective packaging, might damage the components or the chassis backplane.

If you do not install your C300 System and components immediately, Dell Networking recommends you properly store components (including all extra field-replaceable parts) until you are ready to install them.

Follow these indoor storage guidelines:

- Storage temperature should remain constant ranging from -40°F to 158°F (-40°C to 70°C).
- Non-condensing relative humidity should be maintained with 5 to 95%.
- Store on a dry floor, away from direct sunlight, heat, and air conditioning ducts.
- Store in a dust-free environment.

Installing C300 Fan Tray

The C300 chassis contains one field-replaceable fan tray. There are two types of fan tray that may be installed: C300 variable speed fan tray contains six fans that run at varying speeds depending on system temperature, C300 fixed speed fan tray contains six fans that run at a constant speed. For both types of trays, air flows through the C300 system toward the fans (right to left) and is exhausted on the fan-side of the chassis. The fan tray is accessible from the front of the chassis.

Contact Dell Networking Technical Support if you have questions concerning the fan tray for your system.





-  **NOTE:** To ensure proper temperature and airflow control, the fan tray must always be installed and operating properly.
-  **NOTE:** The C300 does not have an air filter so take special care in making sure that the installation site and the chassis itself are cleaned regularly.

Figure 4-1. Inserting the Fan Tray

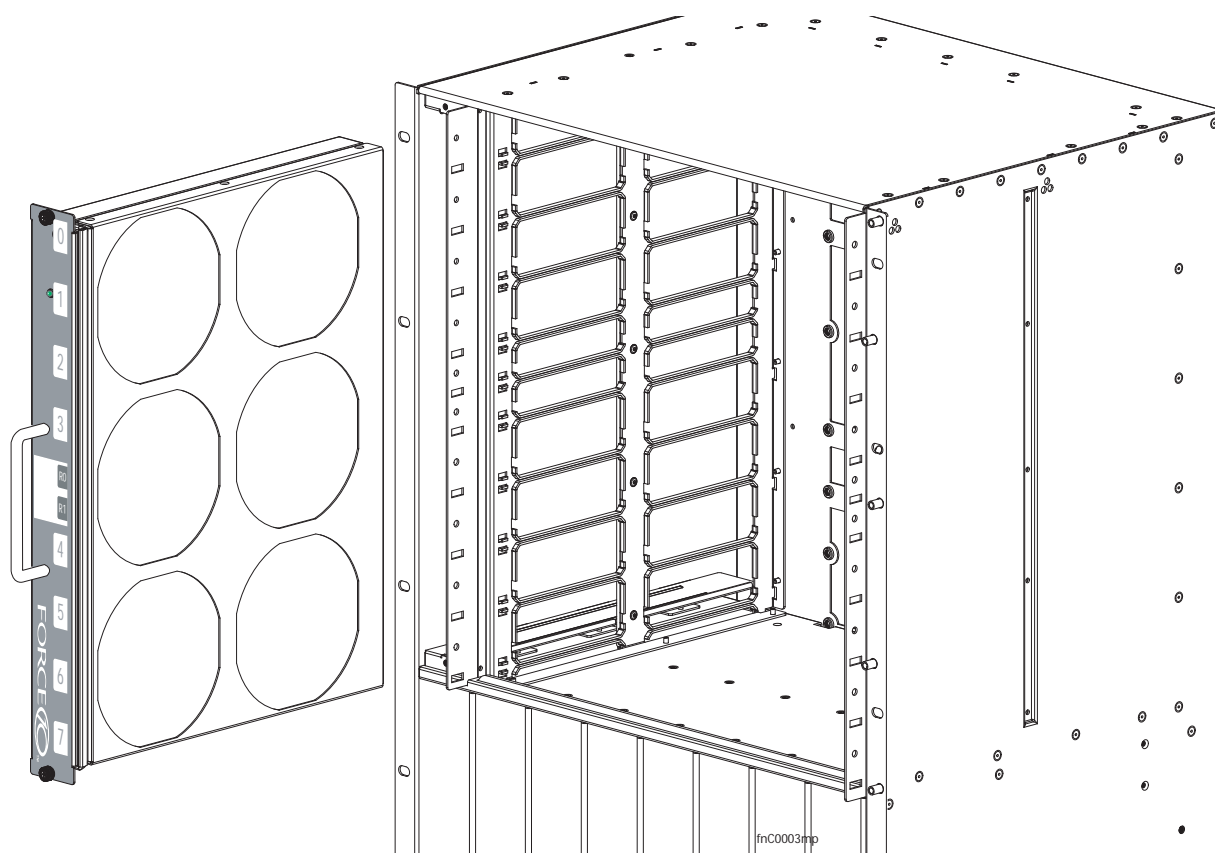

To install the fan tray:

Step	Task
1	Slide the connector end into the fan slot (see Figure 4-1).
2	Gently push on the front of the tray until it stops. The fan tray should be flush with the chassis.
3	Use a #2 Phillips screwdriver to secure the fan tray into place by tightening the screws at the top and bottom of the fan tray.

 **NOTE:** The fan tray LED will remain lit when the chassis is up and the fan tray is functioning properly.

Removing the Fan Tray

A fan tray failure or a failure of a fan within a fan tray is recognized by a red fan tray LED, a lit RPM alarm LED, and, if configured, an SNMP trap and alarm event. The failure requires a replacement of the entire fan tray. While you replace the fan tray, the C300 system operates safely for approximately two (2) minutes at an ambient temperature of 77° F (25° C).

To remove the fan tray, you must be able to pull the fan tray completely out of the slot (at least 20 inches)

 **NOTE:** The fan tray must always be installed to ensure proper temperature and airflow control.

 **CAUTION:** Fan blades rotate at high speeds and may cause injury if touched. Adhere to the following instructions to avoid possible injury.

To remove the fan tray:

Step	Task
1	Unscrew the retaining screws at the top and bottom of the fan tray.
2	Use the handle to pull the fan tray out approximately two inches from the back of the chassis (Figure 4-1). Wait until the fan blades stop rotating (up to 30 seconds), then completely remove the fan tray.

Fan Speed

C300 variable speed fan speed is driven by temperatures measured at the sensor in the fan tray alone. The sensor is located on the fan tray controller located in the fan tray. [Table 4-1](#) shows the sensor temperature that determines the fan speed.

Table 4-1. Fan Speed and Temperature

Degrees Celsius	Fan Speed
Less than 45° C	(Low) 2400 RPM
Between 45 and 55° C	(Med) 3200RPM
Above 55° C	(High) 4000 RPM

C300 fixed speed fan speed is constant and does not change with temperature.

Installing RPMs and Line Cards

The C300 System accommodates eight line cards and two RPMs.

Route Processor Modules

The C300 system requires the installation of at least one Route Processor Module (RPM); two are recommended.

- One RPM provides 48 Gigabits of bandwidth to each line card.
- Two RPMs provides 96 Gigabits of bandwidth to each line card.

RPMs are designed to be installed in either the R0 or R1 slot (see [Figure 2-1](#)). Do not force RPMs into line cards slots. RPMs are keyed differently than line cards to prevent improper installation.

 **NOTE:** If your system contains two RPMs, both RPMs must contain the same software image.

RPM Label and LEDs

[Table 5-1](#) describes the RPM LED states and the RPM front panel.

Table 5-1. RPM Front Panel and LED Descriptions

Section	Label	Description
Management	Console Port	Use this RJ-45 jack for the initial system boot, as well as system configuration and monitoring. Modem connection is not supported on the Console.
	10/100/1000 Ethernet	Use this non-routable Ethernet port to download images and manage the system. FTP and Telnet operations are supported. This port is an RJ-45. Port LEDs: L/A: Blinking Amber: 100M speed Solid Amber: 1G speed Off: 10M speed Speed: Blinking Green: Link detected/ Activity Solid Green: Link detected/ No Activity Off: No Link/ Card Offline
Alarm LED		Red: Major Alarm—a critical condition exists (such as a severe over temperature condition). See Alarms for more information. Flashing red: Minor Alarm—a serious condition exists (such as a single fan failure or a line card failure). See Alarms for more information. Unlit: no alarm conditions.

Table 5-1. RPM Front Panel and LED Descriptions (continued)

Section	Label	Description
Flash	Slot	Use the compact flash card (external compact flash memory card) slot to store and retrieve boot and system images.
	In Use LED	Green: flash memory card is in the process of a read or write process. Do not remove the flash card when the In Use LED is lit. Unlit: not in use.
	Master LED	Indicates that this RPM is the Primary RPM. Green: primary Unlit: secondary/ fatal error/ booting
	Reset Button	Use this recessed reset switch to reset the RPM by inserting a small object, such as a pen tip, to depress the button.
	SFM Active	Green: Switch Fabric is active Unlit: Switch Fabric is inactive
	Status LED	Green: operational Red: card problem state Flashing green: booting/ diagnostics Unlit: in standby mode or is off

Line Cards

Line cards are hot-swappable. Any line card can be inserted into any line card slot. Line card slots are labeled 0 to 7; these labels can be seen when the fan tray is installed. Do not force line cards into the RPM slot.

Line card LEDs are described in the documentation specific to each line card. Refer to the installation documentation that came with the card for to understand LED appearance and meaning.

Blank Panels

Blanks are required in empty slots to control airflow for adequate system cooling, personal safety, and EMI containment during operation.

The blank panels do not have board components or connector pins. Align the blank with the guides and gently slide toward the backplane.

 **NOTE:** All chassis slots must be installed with operational modules or blanks. Always replace cards and blank panels immediately.

Installing the RPMs and Line Cards

 **WARNING:** Electrostatic discharge (ESD) damage can occur when components are mishandled. Always wear an ESD-preventive wrist or foot-heel ground strap when handling RPMs or line cards. Place RPMs and line cards on an antistatic surface when they are not installed.

 **NOTE:** Unlock the levers before inserting the line card into to chassis. Fully engage the locking mechanism once the card has been inserted; not doing so will cause damage to the card below when that card is inserted.

NOTE: The fan tray face panel has slot number markings for the RPMs and line cards. Insert the fan tray before the line cards to simplify RPM and line card installation.

Step	Task
1	Extend the left and right card levers by first pressing gently down on the thumb tabs (see Figure 5-1) in the ejector levers and then pulling the ejector levers simultaneously until they are in the open position. See Figure 5-2 .

Figure 5-1. Depress the thumb tabs



Figure 5-2. Extend the levers



- 2 Hold the card assembly by the metal carrier edges. Avoid touching the printed circuit board and connector pins.
- 3 Align the card with the guide, and gently slide it into any line card slot until the card is about halfway into the slot.
NOTE: Use the markings on the fan tray to determine which slots are for the RPMs and which are for the line cards.
- 4 Continue sliding the line card until you feel the connectors engage with the chassis backplane.

Step	Task
5	Rotate the levers towards the card to seat the backplane connectors and line card in place. Push on the knurled section of the levers until the thumb tabs pop up and lock the unit in place. See Figure 5-3 and Figure 5-4 .

Figure 5-3. Close the levers



Figure 5-4. Press the knurled section of the lever



NOTE: Installing a card without fully engaging the locking mechanism will damage the EMI seal on the card below it when that card is inserted.

- 6 Install a blank panel in all slots that do not have a card and secure it with the screws provided.

NOTE: The blank panels for RPMs and line cards are different sizes (RPM blanks are smaller); be sure that blank panels are installed in the correct slots.

Figure 5-5. Installing a Line Card

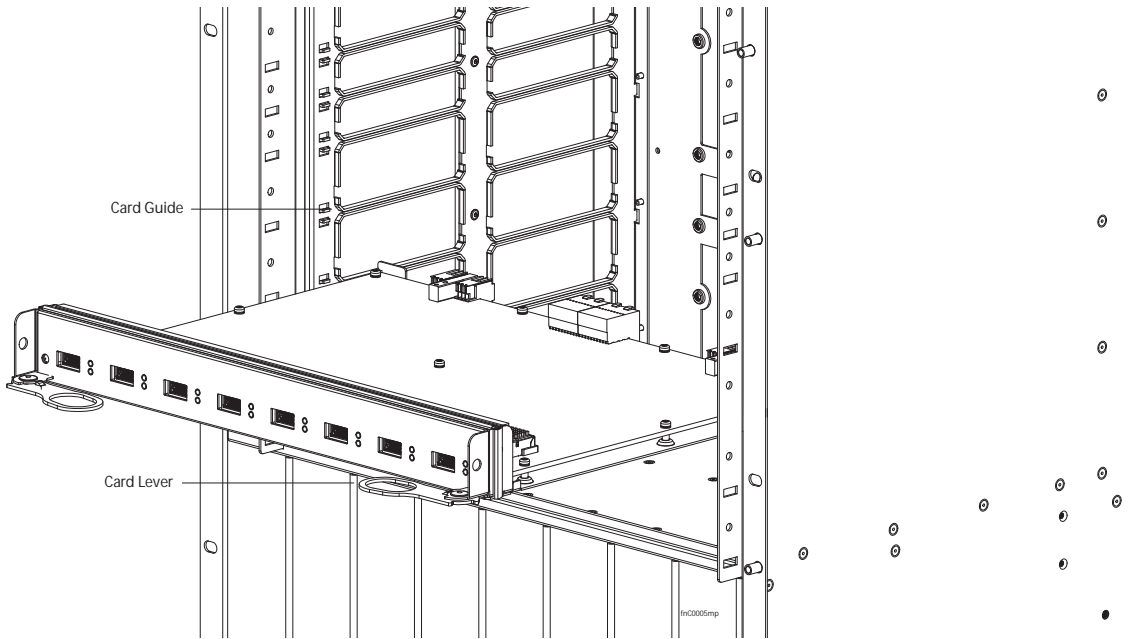
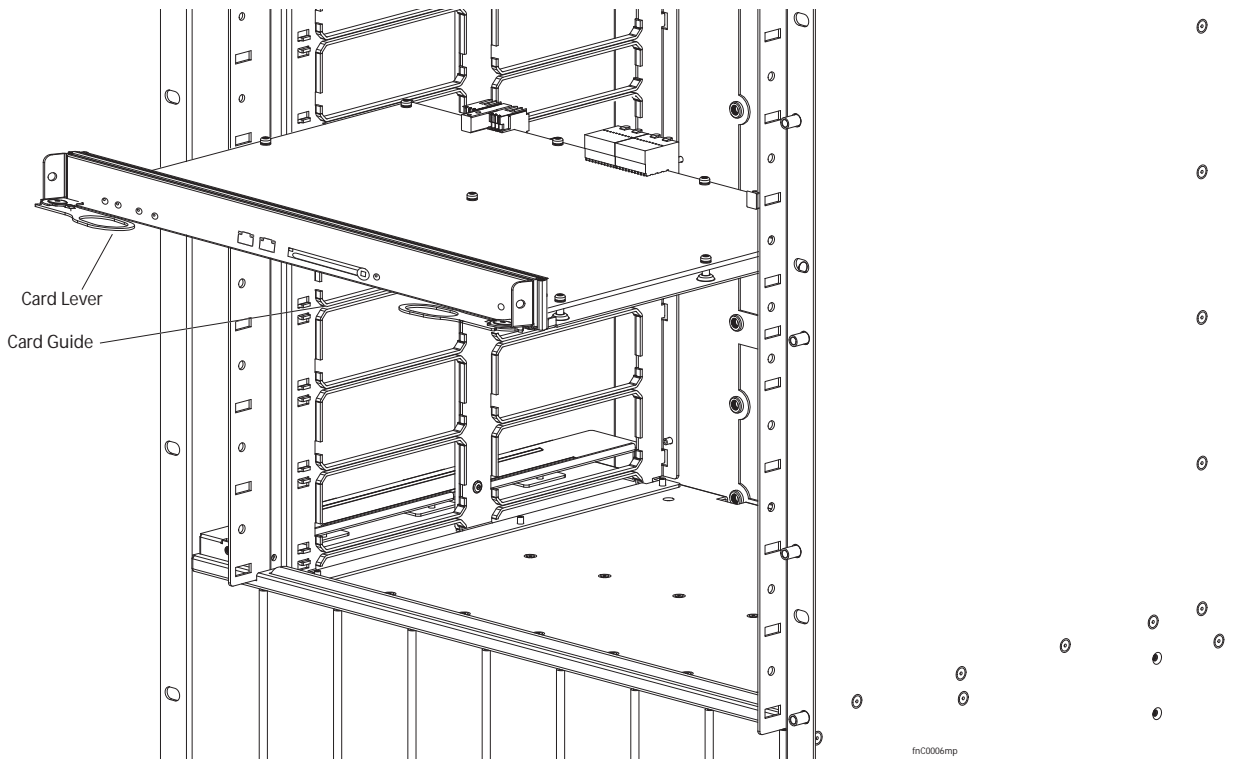

Figure 5-6. Installing an RPM



RPM Cables

Connecting the Console Port

The console port is an asynchronous serial port. If you connect a device to these ports, it must be capable of asynchronous transmission. Your terminal or terminal emulation mode must be set to VT100 with the following settings:

- 9600 baud rate (To avoid autobaud input, the default is set to a 9600 bps.)
- No parity
- 8 data bits
- 1 stop bit
- Window Terminal Emulator option set to **NO**
- 24 lines X 80 characters
- No flow control

Cable and Adapter Pin Assignments

Use the C300 System Console port on the RPM to connect to a terminal port, PC serial port, or a terminal server to configure and monitor your system. An RJ-45 Ethernet cable is required to connect to the Ethernet port.

The Console port is an RJ-45, the pinouts of which are shown in [Figure 6-1](#).

Figure 6-1. Pinouts for an RJ-45 Connector End of Adaptors

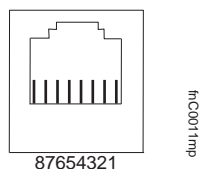

[Table 6-1](#) displays the RJ-45 console port pin assignments.

Table 6-1. Console Port (RJ-45) Pin Assignments

Pin	Signal	Input/Output
1	NC (unused)	-
2	DTR	Output
3	TxD	Output
4	GND	-
5	GND	-
6	RxD	Input
7	DSR	Input
8	NC (unused)	-

Accessing the Console with a DB-9 Adapter

You can connect to the console using a RJ-45 to RJ-45 rollover cable and a RJ-45 to DB-9 female DTE adapter (labeled “TERMINAL”) to a terminal server (for example, PC). [Table 6-2](#) lists the pin assignments.

Table 6-2. Pin Assignments Between the C300 Console and a DTE Terminal Server

C300 System Console Port	RJ-45 to RJ-45 Rollover Cable		RJ-45 to DB-9 Adapter	Terminal Server Device
	Signal	RJ-45 pinout	RJ-45 Pinout	
RTS	1	8	8	CTS
DTR	2	7	6	DSR
TxD	3	6	2	RxD
GND	4	5	5	GND
GND	5	4	5	GND
RxD	6	3	3	TxD
DSR	7	2	4	DTR
CTS	8	1	7	RTS

Accessing the Console with a DB-25 Adapter

You can connect to the console using a RJ-45 to RJ-45 rollover cable and a RJ-45 to a DB-25 female DTE adapter. [Table 6-3](#) lists the pin assignments.

Table 6-3. Pin Assignments Between C300 Console and DB-25 Adapter

C300 System Console Port	RJ-45 to RJ-45 Rollover Cable		RJ-45 to DB-25 Modem Adapter	Terminal Server Device
Signal	RJ-45 Pinout	RJ-45 Pinout	DB-25 Pinout	Signal
RTS	1	8	5	CTS
DTR	2	7	6	DSR
TxD	3	6	3	RxD
GND	4	5	7	GND
GND	5	4	7	GND
RxD	6	3	2	TxD
DSR	7	2	20	DTR
CTS	8	1		RTS

Installing AC Power Supplies

The C300 has eight power supply slots at the front-bottom of the chassis ([Figure 7-1](#)). There are two types of power supplies: Power Supply 1200W-AC and Power Supply 1600W-AC. The slots accept either of the AC Power Supply Units (PSUs).

CAUTION: Do not install the Power Supply 1200W-AC and Power Supply 1600W-AC in the same chassis. The line cards will power down and data may be lost.

- The minimum and the redundant power supplies required to operate is listed in the table below. Dell Networking recommends the redundancy configuration. Additional power supplies are required to enable Power over Ethernet (PoE) or Power over Ethernet Plus (PoE+). See [Power Over Ethernet \(PoE\)](#).

	Voltage	Minimum PSUs	Minimum with Redundant PSUs
Power Supply 1200W-AC/Power Supply 1600W-AC	100-120	2	3
Power Supply 1200W-AC	200-240	2	3
Power Supply 1600W-AC	200-240	1	2

- To protect against high-voltage shock, install a power supply blank on all unused power supply slots.
- Connect the C300 AC power supply to the appropriate branch circuit protection as defined by local electrical codes.
- Verify that the remote power source complies with the system input power specifications in the section [System Specifications](#)

WARNING: The C300 does not have a main disconnect device installed. It is the responsibility of the installer to provide a suitable disconnecting device in the building installation and ensure that it is located/installed near the equipment and is easily accessible.

Figure 7-1. Power Supply Location

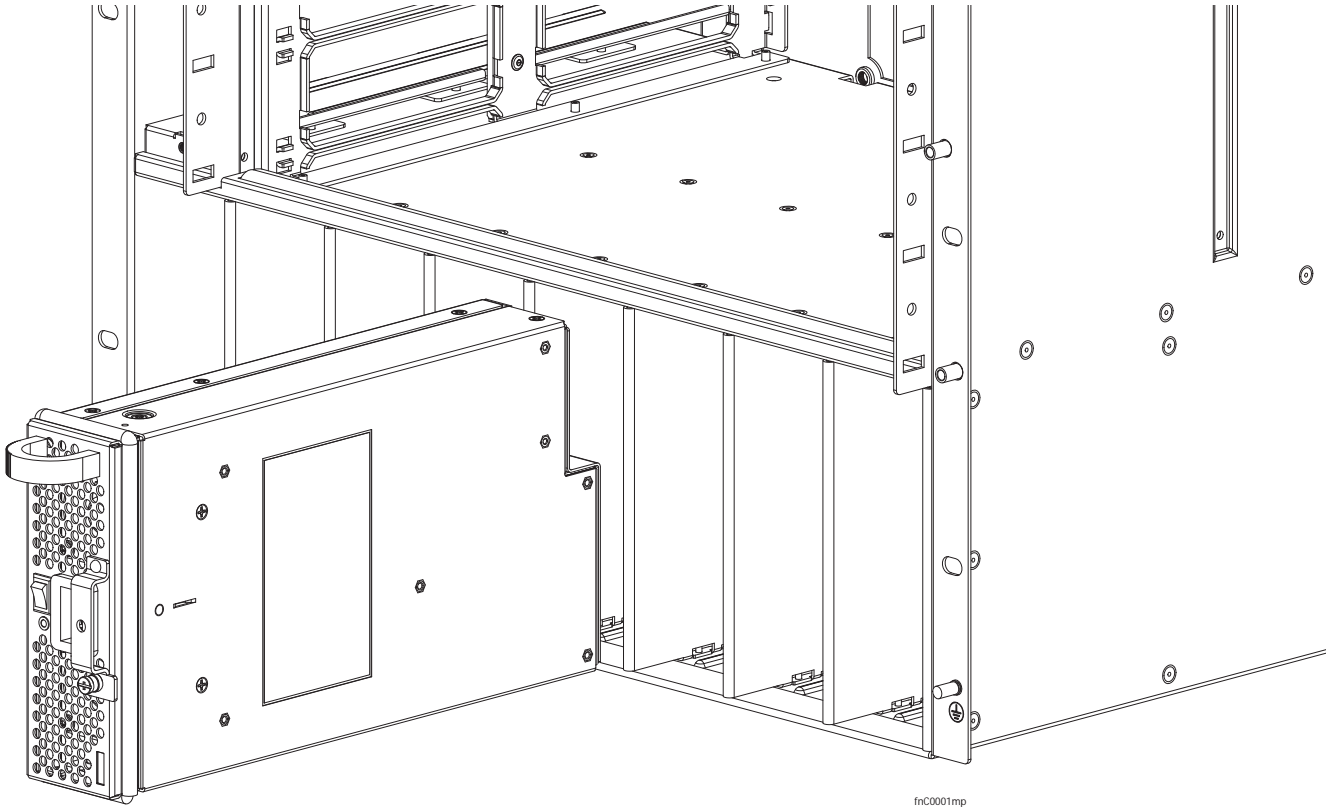
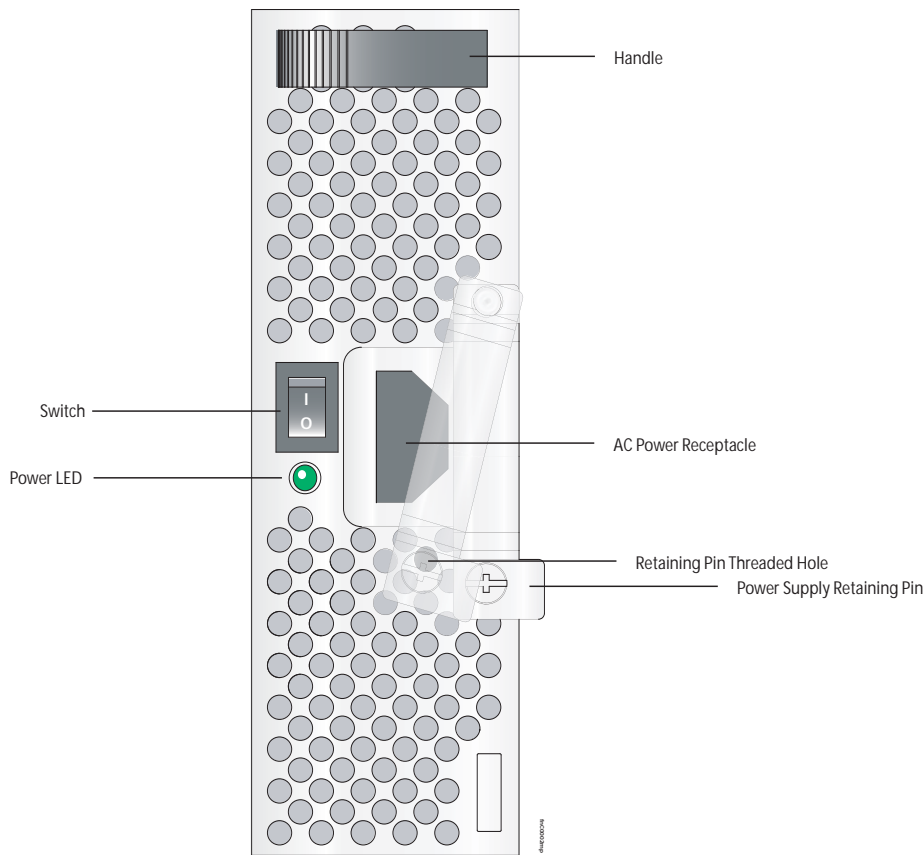

Figure 7-2. AC Power Supply



Each AC power supply has one LED as described in [Table 7-1](#). This LED does not function unless an RPM is installed.

Table 7-1. Power Supply Unit LED Description

Status	Description
Off	The unit is off.
Flashing Green	Warning: the unit is beyond temperature and/or current limits.
Solid Green	The unit is functioning properly
Flashing Red	The unit has failed, possibly due to temperature or current beyond its limits.
Solid Red	The unit is switched on but either unplugged or has low input voltage.

NOTE: For a unit LED to light red, there must be at least one other unit operating in the chassis.

NOTE: If there is a failure in the power supply, it must be replaced. Power supplies are not field serviceable.

Installing the AC Power Supply

⚠ WARNING: Use only the power cord supplied with the power supply. Do not supply power to your C300 system until the power supplies, blank panels, fan tray, RPMs, and line cards have been installed.

⚠ WARNING: The C300 operates in either of two voltage ranges. Each range supports a different power supply configuration. As a safety precaution, do not install more than the recommended maximum number of PSUs (given by the table below), as this causes high leakage current. Install blank panels in all unused PSU slots.

Voltage	Frequency	Maximum PSU
100 - 120	50/60Hz	7 primary + 1 redundant
200 - 240	50/60Hz	7 primary + 1 redundant

WARNING:

🔍 NOTE: For system input power requirements see [System Specifications](#).

You can install any AC power supply into any power supply slot. Dell Networking recommends installing power supplies starting from the left side of the chassis, leaving no blank slots between units.

To install an AC power supply:

Step	Task
1	Verify the switch is in the OFF (bottom) position.
2	Slide the power supply into the left most power supply slot. See Figure 7-1 for correct orientation.
3	Plug the power cord into the power receptacle in the face of the power supply. See Figure 7-2 for location.
4	Plug the power cord into an AC power outlet.
5	Repeat steps 1 through 4 for the remaining power supplies.

Power Cord Requirements

If using a power cord other than a Dell Networking supplied power cord, the power source end of the power cord must have an appropriately sized plug that complies with your local electrical codes. Conductor size must also conform to your local electrical codes.

⚠ CAUTION: The power cord is the main power disconnect device; ensure that the socket-outlet is located/installed near the equipment and is easily accessible.

Power Over Ethernet (PoE)

The C-Series can transmit power to Ethernet devices over the signal pairs of an Unshielded Twisted Pair (UTP) cable. A maximum of 15.4 Watts (at 48 Volts) can be transmitted over a link.

The chassis transmits power to connected IEEE 802.3af-compliant devices via ports that are enabled with PoE. A minimum of four AC power supplies are required to enable PoE, and 96 ports can be enabled per PSU, starting at the fourth, as described in [Table 7-2](#).

Table 7-2. PoE Ports per Power Supply 1200W-AC

Power Supply Units	Max PoE Ports
1	—
2	—
3	System Redundancy
4	96
5	192
6	288
7	384
8	PoE Redundancy

Power Over Ethernet Plus (PoE+)

The C-Series can transmit power to Ethernet devices over the signal pairs of an Unshielded Twisted Pair (UTP) cable. A maximum of 30.0 Watts (at 53 Volts) can be transmitted over a link. The chassis transmits power to connected IEEE 802.3at-compliant devices via ports that are enabled with PoE+. A minimum of three Power Supply 1600W-AC power supplies are required to enable PoE+. The higher power of PoE+ (30W/port) is available only with Power Supply 1600W-AC and the PoE+ line card.

Table 7-3. Maximum PoE+ Ports Support

Power Supply Units	Max PoE+ Ports	
	Power Supply 1600W-AC at highline	Power Supply 1600W-AC at lowline
1	—	—
2	System Redundancy	—
3	53	System Redundancy
4	106	49
5	160	98
6	213	147
7	266	197
8	320	237

Installing DC Power Entry Modules

The C300 has eight supply slots at the front-bottom of the chassis (Figure 8-2). The slots accept either AC Power Supplies (PSUs) or DC Power Entry Modules (PEMs). Dell Networking does not support the use of a combination of AC and DC.

- If you select DC, the C300 requires at least one DC PEM for operation, but Dell Networking recommends a one-plus-one redundancy configuration. Those DC PEMs are inserted in slots 0 and 7.
- To protect against high-voltage shock, install a supply blank on all unused supply slots.

 **NOTE:** The C300 DC Power Entry Module does not support PoE or PoE+ line cards.

 **NOTE:** Some CH-C300 chassis may require Dell Networking assistance when using some DC power supplies. Please contact the Dell Networking TAC if you experience any difficulty during installation.

Recommended Normal Operating Conditions

Table 8-1. Input voltage

Input Ranges	Maximum
-44V (minimum)	1408 watts
-48V (typical)	1536 watts
-55V (maximum)	1760 watts

Table 8-2. Operating Ranges

Ambient Temperature	
Operating Range	-5° C to +40° C
Storage Range	-40° C to +70 ° C
Humidity	
Operating Range	5-85% RH
Storage Range	5-90% RH

Redundancy

For full facility redundancy, install two DC PEMs. Each PEM must be attached to an independent source with a dedicated circuit breaker sized in accordance with your local building and electrical safety codes.

Cable and Connector Requirements

You must provide your own cables to connect to a remote source (a circuit breaker panel, for example) in your equipment rack or facility. Cables must be sized to meet the following criteria:

- Rated for 60A service to allow for a fully loaded C300 system per NEC in the United States or internationally, per local safety codes.
- Limit voltage drop across the cable length to 0.5V or less.

Apply a coat of anti-oxidant paste to unplated metal contact surfaces before you make the cable connections. File unplated connectors, braided straps, and bus bars to a shiny finish. It is not necessary to file and coat tinned, solder plated, or silver-plated connectors or other plated connection surfaces, such as those on the PEM studs.

NOTE: Take precautions against over-tightening the screws or nuts on this device.

Installing a DC PEM

Step	Task
1	Turn the remote power source (the circuit breaker panel) to the OFF position.
2	Turn the over-current switch (located on the PEM front panel) to the OFF position.
3	Loosen the PEM safety cover retaining screw and remove the cover (Figure 8-1).

Figure 8-1. DC PEM Faceplate

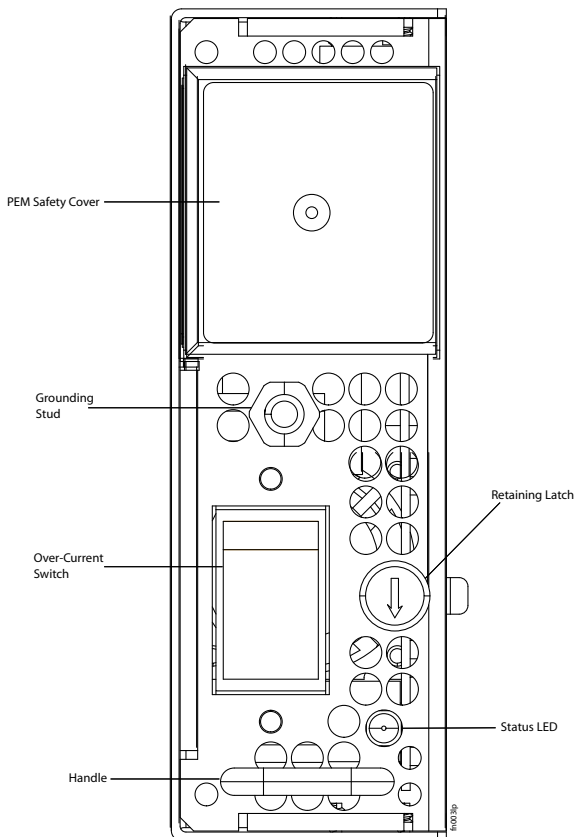

Step	Task (continued)
4	Slide the PEM into slot 0 or 7 (see Figure 8-2). If you are installing redundant PEMs, install in both slots 0 and 7.



 **NOTE:** Fill all empty slots with blank panels.

Figure 8-2. Insert 2 DC PEMs in Slots 0 and 7

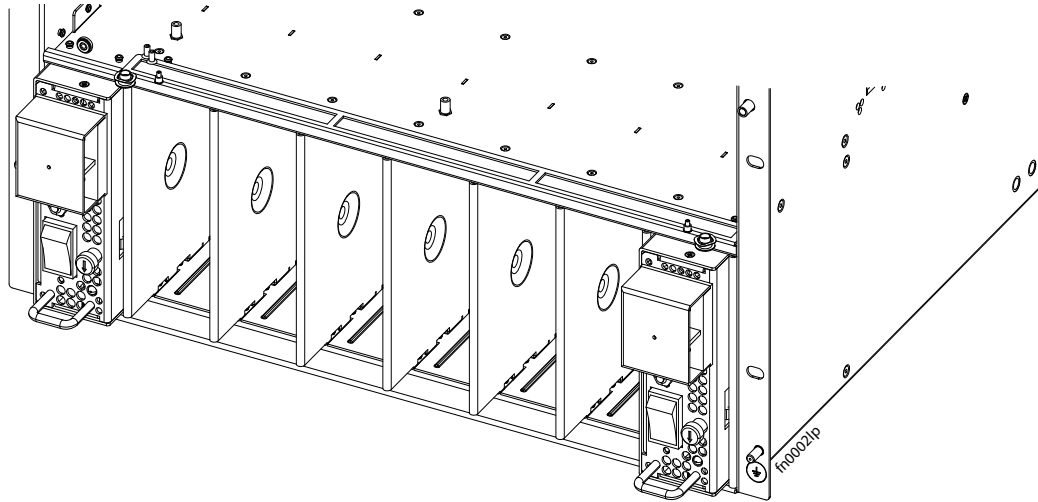

5 Secure the PEM in place by tightening the retaining latch on each module so that the arrow points down ([Figure 8-2](#)).

6 Secure the chassis ground connection:

 **WARNING:** You must complete the ground connection before proceeding with any other PEM connection.

- Locate the chassis ground connector stud on the PEM front panel (see [Figure 8-3](#)). It is the single stud below the safety cover.
- Remove the nut and washer from the ground stud.
- Apply a coat of anti-oxidant paste to the connector stud, if required.
- Install the grounding cable. **This cable is typically green or green and yellow.**

 **NOTE:** Termination points require UL-listed 1-hole lug with a 1/4-inch hole.

- Replace the washer and nut on the stud.
- Secure the nut with a nut driver or torque wrench (not to exceed 4 ft/lbs).
- Connect the opposite end of the grounding cable to the appropriate nearest grounding.

Step	Task (continued)
7	Remove the outer nuts and washers from each of the remaining studs.
8	<p>Connect the -48 VDC and Return cables from each PEM to the remote sources.</p> <ol style="list-style-type: none"> Verify that the remote source is in the OFF position. Locate the appropriate studs on the PEM front panel. <ul style="list-style-type: none"> The two top studs (furthest from the GND) are the return (+48V DC) connection. The cable attached to these studs is typically red. The two bottom studs (closest to GND) are the -48 V DC connection. The cable attached to these studs is typically black. <p>NOTE: Cables must be terminated only with a UL-listed 2-hole lug to accommodate 1/4-inch studs with 3/4-inch spacing.</p> <ol style="list-style-type: none"> Apply a coat of anti-oxidant paste to the connector studs, if required. Replace the washers and nuts on the studs. Route the terminated cables out toward the rack rail. Secure the nuts with a nut driver or torque wrench (not to exceed 4 ft/lbs).

Figure 8-3. Grounding

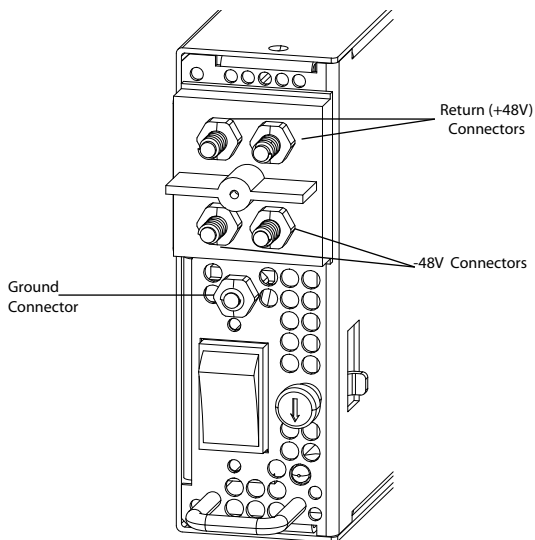

Step	Task (continued)
9	<p>Replace the safety cover and tighten the captive screw.</p> <p>Note that the safety cover can be rotated to accommodate system configurations.</p>
10	Turn the Over-Current Protector to the ON position (Figure 8-1).
11	Turn the remote source (the circuit breaker panel) to the ON position.

Status LED

The status LED indicates the condition of the PEM.

Table 8-3. Status LED Descriptions

LED Display	Meaning	Description
Off	Off	No input voltage is present, or the circuit is turned off.
Flashing Green	Over-Current Warning	The load current is above the warning level threshold. This warning takes precedence over the temperature warning.
Flashing Green	Over-Temperature Warning	The temperature is above the temperature warning threshold.
Solid Green	On	The PEM is running normally.

Removing a DC PEM

The left chassis PEM slot is labelled “0” and the right chassis PEM slot is labelled “1.” For full redundancy, each PEM must be attached to a dedicated circuit breaker. For example, PEM “0” connects to circuit breaker “0” and PEM “1” connects to circuit breaker “1.”

 **WARNING:** Prevent exposure and contact with hazardous voltages. Do not attempt to operate this system with the safety cover removed.

Step	Task
1	Switch the Over Current Protector (located on the PEM front panel) to the OFF position.
2	Turn off the PEM. Ensure that the remote source is in the OFF position and that the PEM Status LED and Pwr In OK LED are off.
3	Loosen the retaining screw and remove PEM safety cover (see Figure 8-1).
4	Disconnect cables attached to the PEM.
5	Slide the PEM out of the slot.
6	If you are not replacing the PEM, close the empty slot with a blank panels.

Powering Up

Before you supply power to the chassis, Dell Networking recommends that you re-inspect your equipment rack and chassis. Verify that:

- The equipment rack is properly secured and grounded.
- The chassis is bolted and secured into your equipment rack.
- Make sure the ambient temperature around the unit (which may be higher than the room temperature) is within the limit specified for the unit.
- Make sure there is sufficient airflow around the unit.
- Make sure electrical circuits are not overloaded – consider the nameplate rating of all the connected equipment, and make sure you have over current protection.
- At least one supply module at highline or two supply modules at lowline are installed.
- All supply module is properly installed.
- All supply modules are switched to the **OFF** (bottom) position.
- The remote source complies with the input specifications in the section [System Specifications](#).
- Cables connect to the remote source.
- The fan tray is installed and cannot be removed by pulling on the fan tray handle.
- At least one RPM is installed.
- All line cards and RPMs are properly installed and secured.
- All chassis slots are filled. Blank panels and covers are installed in all empty slots.
- Make sure no objects are placed on top of the unit.
- Make sure the equipment is properly grounded.

Supplying

⚠ WARNING: Never operate the C300 System without a fan tray.

⚠ WARNING: The C300 operates in either of two voltage ranges. Each range supports a different supply configuration. As a safety precaution, do not install more than the recommended maximum number of PSUs (given by the table below), as this causes high leakage current. Install blank panels in all unused PSU slots.

Voltage	Frequency	Maximum PSU
100 -120	50/60Hz	7 primary + 1 redundant
200 - 240	50/60Hz	7 primary + 1 redundant

To supply the C300 system:

Step	Task
1	Verify that the source complies with the system input requirements in the section System Specifications .
2	Energize the remote source or outlet.
3	Toggle the switch on the AC supplies to the ON (top) position.
4	In an AC Supply, the LEDs should be green. If these LEDs are not lit green: Check that the unit is properly installed. Verify the source. If the supply cannot be verified, off all modules and replace the unit.
5	The fan tray LED should be green (online). You should be able to hear the air flowing through the chassis. If the fans are not operating properly or air is not flowing through the chassis: off all supplies. Verify that the fan tray is properly installed. If the fan tray LED remains unlit, down the unit, and replace the fan tray.

To turn off the AC supplies:

- Toggle the switch two the **OFF** position.
- Unplug the cord from the receptacle on the front of the supply.
- Verify that the LEDs are unlit.

After you supply to the system, the following should occur:

- The fan tray should be operating.
- The green (online) fan tray, RPM, and line card LEDs should be lit and remain lit as long as the system is receiving and is operational.

When you supply to the C300, the system performs a series of -on self tests. RPM and line card LEDs blink as the diagnostic programs run. No user interaction is required at this point. Observe the process on your console monitor. When the boot process is complete, the card LEDs remain online (green) and the console monitor displays the Command Line Interface (CLI) prompt.

 **NOTE:** Do not press any keys or control sequences at any time during the boot process. Doing so may cause the boot process to terminate.

Booting from the **BOOT_USER** Prompt

The initial boot operation automatically brings up the system to the runtime CLI. To interrupt the automatic boot process, issue a break key sequence (CNTL ^ or CNTL~). The console monitor will display the default `BOOT_USER #` prompt. Refer to “Alarms” on page 61 for instructions to continue the boot process.

Removing and Replacing Components

This section provides instructions for removing and replacing the following C300 components:

- [Removing and Replacing the Fan Tray](#)
- [Removing and Replacing Power Supply Units](#)
- [Removing and Replacing a Line Card](#)

When a component fails, the C300 System system triggers an alarm LED (located on the active RPM), disables or changes component Status LEDs, and sends events to the SNMP trap and show alarms table (if this feature is configured). Refer to [Appendix](#) , for more information on alarms.

 **WARNING:** Electrostatic discharge (ESD) damage can occur when components are mishandled. Always wear an ESD-preventive wrist or ankle strap when handling RPMs and line cards. Connect the ESD strap to the grounding plug located on the front of the chassis. Place RPMs and line cards on an antistatic surface and anti-static bags when they are not installed.

Removing and Replacing the Fan Tray

A fan tray failure or a failure of a fan within a fan tray is recognized by a red fan tray LED, a lit RPM alarm LED, and, if configured, an SNMP trap and alarm event. The failure requires a replacement of the entire fan tray. While you replace the fan tray, the C300 system will operate safely for approximately two (2) minutes at an ambient temperature of 77° F (25° C).

To remove and replace the fan tray, you must be able to pull the fan tray completely out of the slot (at least 20 inches).

 **WARNING:** Fan blades rotate at high speeds and may cause injury if touched. Adhere to the following instructions to avoid possible injury.

 **WARNING:** To ensure proper temperature and airflow control, the fan tray must always be installed.

Figure 10-1. Fan Tray (Left)

To remove and replace the fan tray:

Step	Task
1	Unscrew the retaining screws at the top and bottom of the fan tray.
2	Use the handle to pull the fan tray out approximately two inches from the chassis. Wait 30 seconds, until the fan blades stop rotating, then completely remove the fan tray.
3	Insert the new fan tray into the chassis. Guide the tray firmly into the slot until it stops and the handle end is flush with the chassis.
4	Secure the fan tray into place by tightening the screws at the top and bottom of the fan tray using a #2 Phillips screwdriver.

Removing and Replacing Power Supply Units

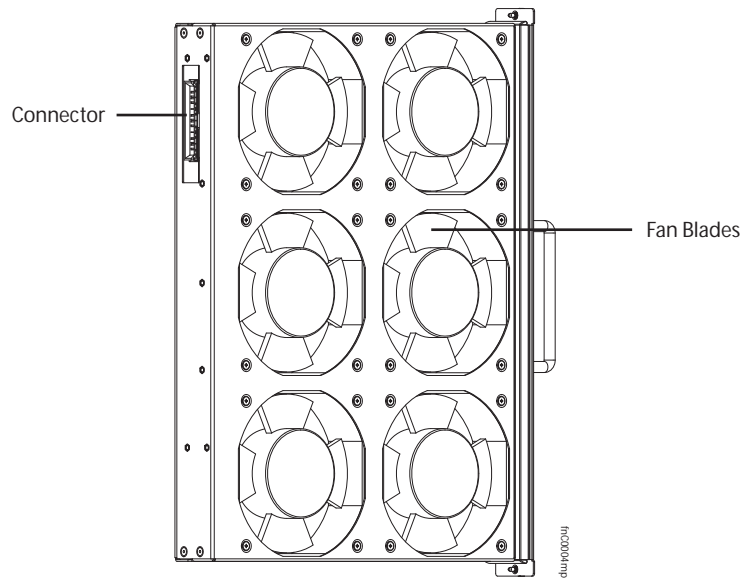
WARNING: Do not remove a panel blank unless you are ready to install a power supply into that slot. After removing a power supply, immediately place a panel blank in the empty slot. Blanks are required to control airflow and electromagnetic interference.

CAUTION: Do not install the Power Supply 1200W-AC and Power Supply 1600W-AC in the same chassis. The line cards will power down and data may be lost.

A power supply failure is recognized by a red LED, a lit RPM alarm LED, and, if configured, an SNMP trap. If you are operating your C300 chassis with a redundant power supply, you can install, remove, or replace a power supply without affecting system operation. If you are operating your C300 system with only two power supplies (the minimum), you must completely turn off the system to replace a power supply.

NOTE: If a power supply fails, the entire unit must be replaced. There are no field serviceable parts inside the unit.

To remove and replace a supply:

Step	Task
1	If the chassis is in the non-redundant power supply configuration, shut down the chassis. If you are removing a redundant power supply, toggle the switch on the power supply to the OFF (bottom) position.
2	If applicable, disconnect the power cable from the AC power source and the front of the power supply.
3	Pull the power supply out of the slot using the handle.
4	If you are not replacing the power supply, insert a panel blank. See Figure 2-1 for the correct orientation.
5	Toggle the switch on the replacement power supply to the OFF position.
6	Slide the new power supply into the power supply slot. See Figure 7-1 for the correct orientation.
7	Plug the AC power cord into the power receptacle in the face of the power supply. See Figure 7-2 for the location.
8	Plug the AC power cord into an AC outlet.
9	Toggle the switch on the power supply to the ON (top) position.
10	Turn up the chassis if necessary.

Removing and Replacing a Line Card

 **WARNING:** Do not remove a panel blank unless you are ready to install a line card into that slot. After removing a line card, immediately place a panel blank in the empty slot. Blanks are required to control airflow and electromagnetic interference.

You can add, replace, or remove C300 line cards without interrupting the system power or system operations.

To remove and replace C300 line cards:

Step	Task
1	Unplug the network interface cables connected to the line card.

Step Task (continued)

- 2 Extend the left and right card levers by first pressing gently down on the thumb tabs (see [Figure 10-2](#)) in the ejector levers and then pulling the ejector levers simultaneously until they are in the open position. See [Figure 10-3](#).

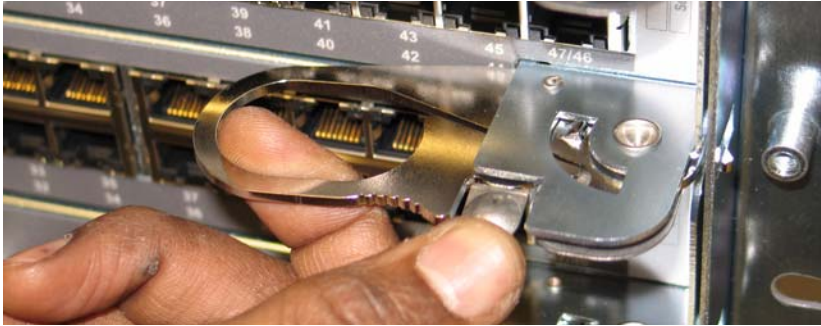
Figure 10-2. Depress the thumb tabs**Figure 10-3. Extend the levers**

- 3 Pull the card by the card levers until it is out of the slot. Avoid touching the printed circuit board and connector pins.
- 4 If you are not replacing the card immediately, install a blank panel.
- 5 If you are replacing the card, follow the instructions in [Installing the RPMs and Line Cards](#).

Removing and Replacing an RPM

⚠ WARNING: After removing an RPM, place a panel blank in the empty slot before powering up the chassis. Blanks are required to control airflow and electromagnetic interference.

🔧 NOTE: The C300 requires at least one RPM to operate. The chassis powers down if you remove the only RPM.

To remove and replace a C300 RPM:

- | Step | Task |
|------|--|
| 1 | Unplug any network interface cables connected to the RPM. |
| 2 | Extend the left and right card levers by first pressing gently down on the thumb tabs (see Figure 10-4) in the ejector levers and then pulling the ejector levers simultaneously until they are in the open position. See Figure 10-5 . |

Figure 10-4. Depress the thumb tabs



Figure 10-5. Extend the levers



- | | |
|---|--|
| 3 | Pull the card by the card levers until it is out of the slot. Avoid touching the printed circuit board and connector pins. |
| 4 | If you are not replacing the RPM, insert an RPM blank panel. |
| 5 | If you are replacing the RPM, follow the instructions in Installing the RPMs and Line Cards . |
| 6 | Only after the replacement is installed, power up the chassis. |

Installing the Chassis

Safety Considerations

 **NOTE:** Use an equipment lift or pallet jack when lifting or moving the chassis. Install the chassis into the rack before inserting chassis components. Lift the C300 chassis *only* from the bottom. Lifting by the chassis shelves or power supply openings will damage the chassis.

 **WARNING:** To prevent bodily injury when mounting or servicing this unit in a rack, you must take special precautions to ensure that the system remains stable. The following guidelines are provided to ensure your safety:

- This unit should be mounted at the bottom of the rack if it is the only unit in the rack.
- When mounting this unit in a partially filled rack, load the rack from the bottom to the top with the heaviest component at the bottom of the rack.
- If the rack is provided with stabilizing devices, install the stabilizers before mounting or servicing the unit in the rack.

 **ATTENTION:** Pour éviter toute blessure corporelle pendant les opérations de montage ou de réparation de cette unité en casier, il convient de prendre des précautions spéciales afin de maintenir la stabilité du système. Les directives ci-dessous sont destinées à assurer la protection du personnel:

- Si cette unité constitue la seule unité montée en casier, elle doit être placée dans le bas.
- Si cette unité est montée dans un casier partiellement rempli, charger le casier de bas en haut en plaçant l'élément le plus lourd dans le bas.
- Si le casier est équipé de dispositifs stabilisateurs, installer les stabilisateurs avant de monter ou de réparer l'unité en casier.

 **WARNUNG:** Zur Vermeidung von Körperverletzung beim Anbringen oder Warten dieser Einheit in einem Gestell müssen Sie besondere Vorkehrungen treffen, um sicherzustellen, daß das System stabil bleibt. Die folgenden Richtlinien sollen zur Gewährleistung Ihrer Sicherheit dienen:

- Wenn diese Einheit die einzige im Gestell ist, sollte sie unten im Gestell angebracht werden.
- Bei Anbringung dieser Einheit in einem zum Teil gefüllten Gestell ist das Gestell von unten nach oben zu laden, wobei das schwerste Bauteil unten im Gestell anzubringen ist.
- Wird das Gestell mit Stabilisierungszubehör geliefert, sind zuerst die Stabilisatoren zu installieren, bevor Sie die Einheit im Gestell anbringen oder sie warten.

Installing the Chassis into an Equipment Rack

Follow these steps to install the chassis into a 19-inch equipment rack:

Step	Task
1	<p>Install the equipment rack bar. This bar enables you to easily position the chassis into the rack and stabilizes the chassis.</p> <ul style="list-style-type: none">• Orient the equipment rack bar at the desired location in the rack, with the arrows pointing up and the smooth side facing outward.

Figure 11-1. Installing the Equipment Rack Bar

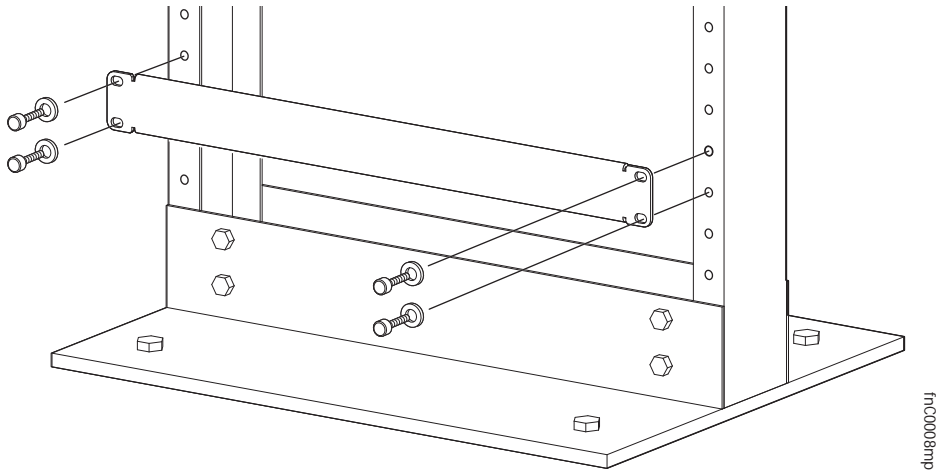

- 2 Attach the bar to the rack (see [Figure 11-1](#)) using the mounting screws provided with your rack.
- 3 Use an equipment lift to align the chassis rack-mount holes with the equipment rack holes, and situate the chassis on top of the equipment rack bar.

Step	Task
4	Insert screws (provided with your rack) through the chassis rack-mounting bracket and into the equipment rack, and tighten them (see Figure 11-2).

Figure 11-2. Rack Mounting the Chassis

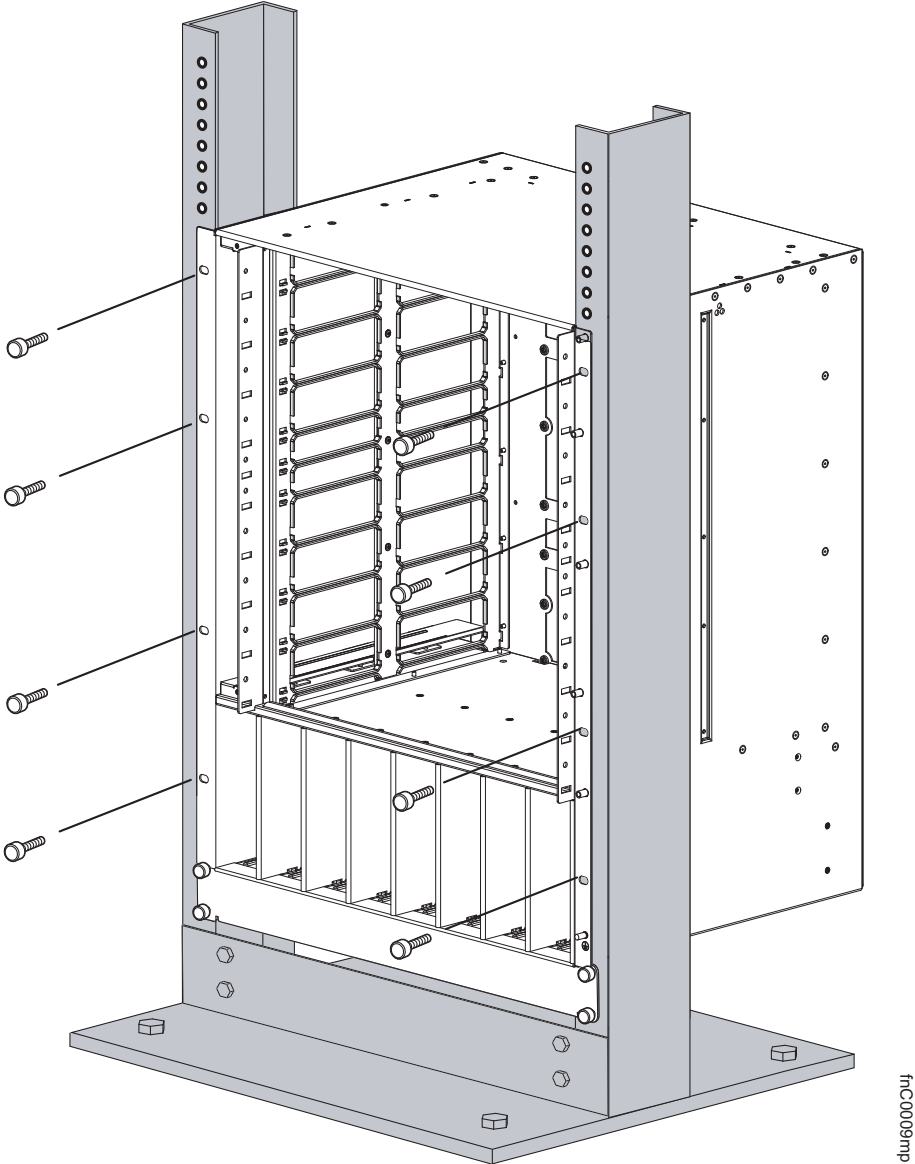

fnC0009mp

System Boot

When you supply power to the C300 system, the system performs a series of on self-tests. RPM and line card Status LEDs blink during initialization. No user interaction is required as long as the boot process proceeds without interruption. Observe the process on your console monitor. When the boot process is complete, the RPM and line card Status LEDs remain online (green) and the console monitor displays the command line interface (CLI) prompt, `FTOS>`.

The RPM cards in the C300 system use a Compact Flash card (external flash memory card) to store and retrieve boot and system images. This is the default storage area for the boot files and the startup configuration file. Upon system boot up or a system reset, the boot process uses parameters stored in non-volatile random access memory (NVRAM) to boot the system.

Each RPM card is equipped with a slot for an external flash memory card (slot0). You can copy the image files and configuration files to the external flash device on the *primary* RPM. You can also begin your boot process by accessing a remote server containing the boot image and system image files.

 **NOTE:** The C300 system supports up to a 40-character file name length, up to a 180-character local file path length, and up to a 256-character remote file path length.

For information about the Compact Flash card, refer to [Chapter 13, The Compact Flash Card](#).



Booting from the BOOT_USER Prompt

To get into the BOOT_USER mode, issue a break control sequence (CNTL+^) to interrupt the automatic boot process or you may enter the mode if you experience boot problems. This mode allows you to modify the parameters necessary to manage the boot process. Only console port access is enabled for the BOOT_USER mode.

The BOOT_USER # prompt appears after an autoboot interruption. This is the default boot prompt, not the CLI prompt.

In some display outputs, you can continue the help screen display by pressing ENTER or can stop the output by entering `q` and then ENTER. You can abbreviate the boot commands by entering only the first letter of a command word. (In the BOOT_USER mode, you cannot press the TAB key to complete commands.) A matching algorithm displays the command starting with the letter or letters you entered. For example, `b` displays the commands starting with the letter `b`, **boot change** and **boot selector**. Entering `s h` displays the **syntax help** information. All commands are case insensitive.

To configure the chassis from the BOOT_USER prompt, use the following commands:

Command	Purpose
help or ?	<ul style="list-style-type: none"> Enter help or ? to display a list of available commands and syntax. Enter syntax help to display syntax information and variable descriptions.
boot change { primary secondary default }	<p>If your configuration displays no pre-configured operating system boot parameters, use the boot change command to edit appropriate fields.</p> <ul style="list-style-type: none"> The primary operating system boot parameters are used in the first attempt to boot the system. The secondary operating system boot parameters are used if the primary operating system boot selection is not available. The default operating system boot parameters are used if the secondary operating system boot parameter is not available. The default parameters always reside on the internal flash drive (flash). <p> NOTE: These parameters, as well as other boot parameters, can be modified in run-time mode</p> <p>When you enter the boot change command, you are prompted for a response.</p> <ul style="list-style-type: none"> Enter a new parameter or press the ENTER key (carriage return) to accept the default parameter. Enter . (period) to clear a field. Enter - (dash) to edit a field above the current cursor position. <p> NOTE: When you enter a new parameter that extends beyond 80 characters, you cannot use the BACKSPACE key to correct any mistakes. If you make a mistake, you must re-enter the parameter.</p>
show bootvar	This command displays the current operating system boot configuration parameters
show bootflash	This command displays information about the current boot ROM.
interface management port config 100m interface management port config 10m interface management port config auto-negotiate interface management port config no auto-negotiate interface management port config full-duplex interface management port config half-duplex interface management port config show	<ul style="list-style-type: none"> Use these commands to set the speed and duplex settings for the Management interface. The default setting is full-duplex and auto-negotiation. Use the interface management port config show command to view the management interface's physical settings.

Command	Purpose <i>(continued)</i>
show interface management ethernet interface management ethernet ip address <i>ip-address ip-address-mask</i>	<ul style="list-style-type: none"> • Use the show interface management ethernet command to display the IP address and network mask of the Management Ethernet port. • If the show command output does not display configured IP address information, use the interface management ethernet ip address <i>ip-address ip-address-mask</i> command to set the IP address of the Management Ethernet port for network (ftp/tftp) operating system boot. Use CIDR block notation for the subnet mask,
boot zero { primary secondary default }	Delete the boot configuration.
reload	Reload the software. The autoboot program initializes and displays self-test results on the console screen.  NOTE: Do not press the break control sequence at any time during the boot/reboot process. Doing so causes the boot process to terminate.

Refer to the *C-Series FTOS Command Line Reference* for BOOT_USER mode commands and commands for run-time modes.

The Compact Flash Card

Each RPM is designed with a slot (slot0:) to accommodate a Compact Flash Card (external compact flash memory card). You can use the Compact Flash Card to store and retrieve boot and system images. For complex configurations, you can copy your configurations onto the Compact Flash Card and then transfer the configuration to other C300 systems in your network.

NOTE: Use only a Dell Networking Compact memory card in your C300 System. Additional memory cards can be purchased from Dell Networking.

Inserting the Compact Flash Card

NOTE: Insert the Compact Flash Card either before system boot or after the system has completed booting and is in run-time mode.

To install the Compact Flash card:

Step	Task
1	Hold the flash card horizontally with the side with the serial number facing up (the numbers should be oriented so you can read them) See Figure 13-1 for the proper orientation.

Figure 13-1. Inserting the Compact Flash Card in RPM

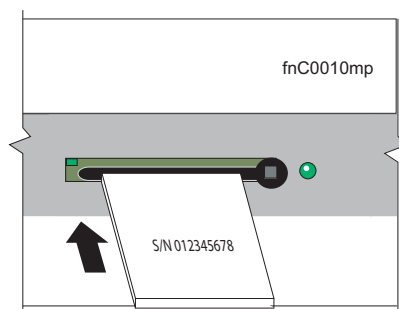

- 2 Insert the flash card into the primary RPM flash slot until the card is completely seated with the connectors at the rear of the slot.

NOTE: Do not force the card into the slot. The slot is designed to prevent improper installation. The In Use LED lights only during read or write operations.

Removing the Compact Flash Card

CAUTION: Do not remove the Compact Flash Card when the In Use LED is lit.

To remove the flash memory card:

Step	Task
1	Make sure that the In Use LED is not lit, and gently depress the flash card in the slot. The card should partially eject out of the slot.
2	Remove the card, and place it in an antistatic bag.

Formatting the Compact Flash Card

New Compact Flash cards must be formatted in the C300 before use.

Flash cards used on systems other than the C300 as well as cards formatted on PCs must be reformatted in the C300 flash slot before they can be used. Formatting erases all information stored on the flash card.

To format the Compact Flash card:

Step	Task
1	Insert the flash card into the flash slot on the primary RPM.
2	In the CLI, enter format slot0:

FTOS supports up to a 40-character file name length, up to a 180-character local file path length, and up to a 256-character remote file path length.

Alarms

The C300 System generates alarms for the following conditions:

- fan tray status
- supply status
- RPMs status
- high temperature on RPMs
- line cards status
- high temperature on line cards

A major alarm is any fault that would render the C300 System non-functional.

A minor alarm is any fault that threatens the operation of the C300 System.

You can monitor alarm conditions on the C300 System system through the console and LEDs. If you configure the SNMP command (`snmp-server enable traps envmon`), the FTOS also sends an SNMP trap.

In the C300 System system, alarms are logged for each occurrence, but the system may not send an event log for multiple occurrences. For example, whenever a module exceeds the shutdown threshold, the module shuts down.

If more than one module exceeds the warning or high temperature thresholds within a five minute period, the system generates one event for all effected modules but alarms are logged for each occurrence. If the modules temperature falls to 5° lower than the warning threshold temperature, the system clears the alarm and an SNMP trap.

Table A-1. Alarm Events and Reporting

Module	Alarm Event	Alarm LED	Reported in event log	Status LED on Module
Fan tray	One fan within the module fails	minor (blinking red)	minor	N/A
	More than one fan within the module fails or hardware failure in the module	major (red)	major	unlit
AC Supplies	Hardware failure in a non-redundant configuration (2 supplies)	major (red)	major	unlit
	Hardware failure in a redundant configuration (3 or more)	minor (amber)	minor	unlit

Table A-1. Alarm Events and Reporting

Module	Alarm Event	Alarm LED	Reported in event log	Status LED on Module
Line Card	Hardware failure	major (red)	major	amber
	Exceeds high temperature limit	major (red)	major	unlit
	Exceeds warning temperature limit	minor (amber)	minor	green
	Individual interface fails	minor (amber)	reported	amber
RPM (Non-redundant Configuration with 1 RPM)				
	Exceeds high temperature limit	major (red)	major	unlit
	Exceeds warning temperature limit	minor (amber)	minor	green
	RPM fails but CP is ok	major (red)	major	amber

AC Supplies and Alarms

During system boot, if a redundant supply is removed or fails, the FTOS generates a minor alarm message.

If only two supplies are installed and one of them fails, the software generates an alarm and an SNMP trap (if configured), and lights the RPM alarm LED and supply LED.

B

System Specifications

Physical Design

Chassis Dimensions

Table B-1. Chassis Dimensions

Parameter	Specifications
Height	22.7 inches (57.66 cm)
Width	17.4 inches (37.58 cm)
Depth	14.4 inches (44.20 cm)
Weight	55 lbs (24.95 kg) with factory installed components 152.27 lbs (69.07 kg) fully loaded
Mounting	Integral rack mount strips for front mounting in a standard 19-inch rack.
Clearance required	Front: 18-inches (46 cm) Rear: 20-inches (51 cm)

Component Dimensions

Table B-2. Component Dimensions

Component	Length (in)	Width (in)	Depth (in)	Weight (lb)
48-port 1G Line Card	15.25	13.75	1.75	5.31
4-port 10G XFP Line Card	15.25	13.75	1.75	5.31
8-port 10G XFP Line Card	15.25	13.75	1.75	5.31
8-port 1G SFP+ Line Card	15.25	13.75	1.75	5.31
48-port 1G SFP Line Card	15.25	13.75	1.75	5.31
48 Port 10/100/1GE-POE+	15.25	13.75	1.75	5.31
48-port 1G PoE Line Card	15.25	13.75	1.75	5.585
46-port FlexMedia Line Card	15.25	13.75	1.75	5.31
46-port FlexMedia PoE Line Card	15.25	13.75	1.75	5.31
C300 RPM	15.25	13.75	1	5.275
Fan Tray	13	1.125	16.125	8.51
Supply Unit	11.75	1.875	5.625	5.065
Line Card Blank Panel	15.25	13.75	1.75	2.94
RPM Blank Panel	15.25	13.75	1	2.75
PSU Blank Panel	11.25	1.875	5.625	1.08

System Specifications

Table B-3. AC Power System Specifications - Power Supply 1600W-AC

Parameter	Specifications
Nominal Input Voltage	100-240 VAC 50/60 Hz
Maximum AC Power Supply Input Current (Based on 1200 W output for 100/120 V and 1600 W output 200/240 V lines)	14 A @ 100 V per AC Power Supply 11 A @ 120 VAC per AC Power Supply 9 A @ 200 VAC per AC Power Supply 7 A @ 240 VAC per AC Power Supply
Maximum System Power Input	9,667 KVA @ 100/120 V 12,596 KVA @ 200/240 V
Maximum Power Consumption	2,707 W @ 100/120 V 2,726 W @ 200/240 V
Maximum Thermal Output at 100/120 V	9,235 BTU/hour
Maximum Thermal Output at 200/240 V	9,299 BTU/hour

Table B-4. AC Power System Specifications - Power Supply 1200W-AC

Parameter	Specifications
Nominal Input Voltage	100-240 VAC 50/60 Hz

Table B-4. AC Power System Specifications - Power Supply 1200W-AC

Maximum AC Power Supply Input Current (Based on 1200 W output for 100/120 V and 1600 W output 200/240 V lines)	14 A @ 100 V per AC Power Supply 11 A @ 120 VAC per AC Power Supply 7 A @ 200 VAC per AC Power Supply 6 A @ 240 VAC per AC Power Supply
Maximum System Power Input	8,274 KVA @ 100/120 V 8,088 KVA @ 200/240 V
Maximum Power Consumption	2,361 W @ 100/120 V 2,175 W @ 200/240 V
Maximum Thermal Output at 100/120 V Maximum Thermal Output at 200/240 V	8,055 BTU/hour 7,420 BTU/hour

Component Power Requirements

Table B-5. Component Power Requirements

Component	Maximum Watts
48 Port 10/100/1GE-POE+	105W
48-port 10/100/1GELine Card	100W
4-port 10G XFP Line Card	120W
8-port 10G XFP Line Card	120W
8-port 10G SFP+ Line Card	120W
48-port 1G SFP Line Card	130W
48-port 10/100/1GE PoE Line Card	100W
46-port FlexMedia Line Card	120W
46-port FlexMedia PoE Line Card	120W
C300 RPM	100W
Fixed speed fan tray	85W
Variable speed fan tray	200W
Power Supply Unit 1200W-AC	1200W
Power Supply Unit 1600W-AC	1200W (low-line) 1600W (high-line)

 **NOTE:** The listed requirement for the PoE version of line cards excludes the required power for PoE, as that requirement is a function of the number and type of PoE devices connected.

 **NOTE:** Additional components may be available for your system, other than those included in the above table. Refer to www.force10networks.com/support/ for the latest information.

Agency Compliance

The C300 system is designed to comply with the following requirements.

USA Federal Communications Commission (FCC) Statement

This equipment has been tested and found to comply with the limits for a Class A digital device, pursuant to Part 15 of the FCC rules. These limits are designated to provide reasonable protection against harmful interference when the equipment is operated in a commercial environment. This equipment generates, uses, and can radiate radio frequency energy. If it is not installed and used in accordance to the instructions, it may cause harmful interference to radio communications. Operation of this equipment in a residential area is likely to cause harmful interference, in which case users will be required to take whatever measures necessary to correct the interference at their own expense.

Properly shielded and grounded cables and connectors must be used in order to meet FCC emission limits. Dell Networking is not responsible for any radio or television interference caused by using other than recommended cables and connectors or by unauthorized changes or modifications in the equipment. Unauthorized changes or modification could void the user's authority to operate the equipment.

This device complies with Part 15 of the FCC Rules. Operation is subject to the following two conditions: (1) this device may not cause harmful interference, and (2) this device must accept any interference received, including interference that may cause undesired operation.

Canadian Department of Communication Statement

Industry Canada Class A emission compliance statement

This Class A digital apparatus complies with Canadian ICES-003.

Avis de conformité à la réglementation d'Industrie Canada

Cet appareil numérique de la classe A est conforme à la norme NMB-003 du Canada.

European Union EMC Directive Conformance Statement

This product is in conformity with the protection requirements of EU Council Directive 2004/108/EC on the approximation of the laws of the Member States relating to electromagnetic compatibility. Force 10 Networks can not accept responsibility for any failure to satisfy the protection requirements resulting from a non-recommended modification of this product, including the fitting of non-Dell Networking option cards.

This product has been tested and found to comply with the limits for Class A Information Technology Equipment according to CISPR 22/ European Standard EN 55022. The limits for Class A equipment were derived for commercial and industrial environments to provide reasonable protection against interference with licensed communication equipment.

⚠ CAUTION: This is a Class A product. In a domestic environment, this device may cause radio interference, in which case, the user may be required to take adequate measures.

European Community Contact

Dell Force10, EMEA - Central
Dahlienweg 19
66265 Heusweiler
Germany

<http://www.force10networks.com/german/>

Tel: +49 172 6802630

Email: EMEA Central Sales

Japan: VCCI Compliance for Class A Equipment

この装置は、情報処理装置等電波障害自主規制協議会（VCCI）の基準に基づくクラスA情報技術装置です。この装置を家庭環境で使用すると電波妨害を引き起こすことがあります。この場合には使用者が適切な対策を講ずるよう要求されることがあります。

This is Class A product based on the standard of the Voluntary Control Council For Interference by Information Technology Equipment (VCCI). If this equipment is used in a domestic environment, radio disturbance may arise. When such trouble occurs, the user may be required to take corrective actions.

⚠ WARNING: AC cords are for use with Dell Networking equipment only. Do not use Dell Networking AC cords with any unauthorized hardware.

本製品に同梱いたしております電源コードセットは、本製品専用です。
 本電源コードセットは、本製品以外の製品ならびに他の用途でご使用いただくことは出来ません。製品本体には同梱された電源コードセットを使用し、他製品の電源コードセットを使用しないで下さい。

Korea (MIC certification)

Korean Class A Warning Statement

이 기기는 업무용으로 전자파 적합등록을 받은 기기 이오니, 판매자 또는 사용자는 이점을 주의하시기 바라며, 만약 잘못 구입하셨을 때에는 구입한 곳에서 비업무용으로 교환하시기 바랍니다.

Korea Certification

A급 기기 (업무용 방송통신기자재)	이 기기는 업무용(A급) 전자파적합기기로서 판매자 또는 사용자는 이 점을 주의하시기 바라며, 가정외의 지역에서 사용하는 것을 목적으로 합니다.
------------------------	---

Korea Information

	 [equipment type]
품명(Product Name)	Ethernet Switch
모델명(Model)	[model number]
신청인(Applicant)	Force10 Networks, Inc.
제조사(Manufacturer)	Delta Networks, (Dongguan) Ltd.
제조년월(Manufacturing Date)	[date]
제조국(Country of Origin)	China

Safety Standards and Compliance Agency Certifications

- CUS UL (60950-1, 1st Edition)

- CSA 60950-1-03, 1st Edition
- EN 60950-1, 1st Edition
- EN 60825-1, 1st Edition
- EN 60825-1 Safety of Laser Products—Part 1: Equipment Classification Requirements and User's Guide
- EN 60825-2 Safety of Laser Products—Part 2: Safety of Optical Fibre Communication Systems
- FDA Regulation 21CFR 1040.10 and 1040.11

Electromagnetic Compatibility (EMC)

Emissions

- Australia/New Zealand: AS/NZS CISPR 22: 2006, Class A
- Canada: ICES-003, Issue-4, Class A
- Europe: EN55022 2006 (CISPR 22: 2006), Class A
- Japan: VCCI V3/ 2007.04 Class A
- USA: FCC CFR47 Part 15, Subpart B, Class A

Immunity

- EN 300 386 V1.3.3: 2005 EMC for Network Equipment
- EN 55024 1998 + A1: 2001 + A2: 2003
 - EN 61000-3-2 Harmonic Current Emissions
 - EN 61000-3-3 Voltage Fluctuations and Flicker
 - EN 61000-4-2 ESD
 - EN 61000-4-3 Radiated Immunity
 - EN 61000-4-4 EFT
 - EN 61000-4-5 Surge
 - EN 61000-4-6 Low Frequency Conducted Immunity

Product Recycling and Disposal

This switch must be recycled or discarded according to applicable local and national regulations. Dell Networking encourages owners of information technology (IT) equipment to responsibly recycle their equipment when it is no longer needed. Dell Networking offers a variety of product return programs and services in several countries to assist equipment owners in recycling their IT products.

Waste Electrical and Electronic Equipment (WEEE) Directive for Recovery, Recycle and Reuse of IT and Telecommunications Products

Dell Networking switches are labeled in accordance with European Directive 2002/96/EC concerning waste electrical and electronic equipment (WEEE). The Directive determines the framework for the return and recycling of used appliances as applicable throughout the European Union. This label, as

shown in [Figure B-1](#), is applied to various products to indicate that the product is not to be thrown away, but rather reclaimed upon end of life per this Directive.

Figure B-1. The European WEEE Symbol



In accordance with the European WEEE Directive, electrical and electronic equipment (EEE) is to be collected separately and to be reused, recycled, or recovered at end of life. Users of EEE with the WEEE marking per Annex IV of the WEEE Directive, as shown above, must not dispose of end of life EEE as unsorted municipal waste, but use the collection framework available to customers for the return, recycling and recovery of WEEE. Customer participation is important to minimize any potential effects of EEE on the environment and human health due to the potential presence of hazardous substances in EEE.

Dell Networking products, which fall within the scope of the WEEE, are labeled with the crossed-out wheeled-bin symbol, as shown above, as required by WEEE.

For information on Dell Networking product recycling offerings, see the WEEE Recycling instructions on iSupport.

For more information, contact the Dell Networking Technical Assistance Center (TAC) (see [Contacting the Technical Assistance Center on page 55](#)).

For California:

Perchlorate Material — Special handling may apply.

See: <http://www.dtsc.ca.gov/hazardouswaste/perchlorate>

The foregoing notice is provided in accordance with California Code of Regulations Title 22, Division 4.5 Chapter 33. Best Management Practices for Perchlorate Materials.



Contacting Technical Support

The iSupport Website

iSupport provides a range of documents and tools to assist you with effectively using Dell Networking equipment and mitigating the impact of network outages. Through iSupport you can obtain technical information regarding Dell Networking products, access to software upgrades and patches, and open and manage your Technical Assistance Center (TAC) cases. Dell Networking iSupport provides integrated, secure access to these services.

Accessing iSupport Services

The URL for iSupport is www.force10networks.com/support/. To access iSupport services you must have a userid and password. If you do not have one, you can request one at the website:

- 1 On the Dell Networking iSupport page, click the **Account Request** link.
- 2 Fill out the User Account Request form, and click **Send**. You will receive your userid and password by E-mail.
- 3 To access iSupport services, click the **Log in** link, and enter your userid and password.

Contacting the Technical Assistance Center

How to Contact Dell Networking TAC	Log in to iSupport at www.force10networks.com/support/ , and select the Service Request tab.
Information to Submit When Opening a Support Case	<ul style="list-style-type: none">• Your name, company name, phone number, and E-mail address• Preferred method of contact• Model number• Serial Number (see Locating Serial Numbers)• Software version number• Symptom description• Screen shots illustrating the symptom, including any error messages. These can include:• Output from the show tech command or the show tech linecard {number} command.• Output from the show trace command or the show trace linecard {number} command.• Console captures showing the error messages.• Console captures showing the troubleshooting steps taken.• Saved messages to a syslog server, if one is used.
Managing Your Case	Log in to iSupport, and select the Service Request tab to view all open cases and RMAs.



Downloading Software Updates	Log in to iSupport, and select the Software Center tab.
Technical Documentation	Log in to iSupport, and select the Documents tab. This page can be accessed without logging in via the Documentation link on the iSupport page.
Contact Information	E-mail: Dell-Force10_Technical_Support@Dell.com Web: www.force10networks.com/support/ Telephone: US and Canada: 866.965.5800 International: 408.965.5800

Locating Serial Numbers

- The chassis serial number is below the barcode on the sticker on the back of the chassis.
- The serial numbers for the RPM, line cards, fan tray, and supply units are below the barcode on the sticker on the front of each component.

Requesting a Hardware Replacement

To request replacement hardware, follow these steps:

Step	Task
1	<p>Determine the part number and serial number of the component. To list the numbers for all components installed in the chassis, use the <code>show inventory</code> command.</p> <p> NOTE: The serial numbers of fan trays and AC supplies will not appear in the hardware inventory listing. Check the failed component for the attached serial number label.</p> <p> NOTE: Quickly reinsert the fan tray back into the chassis once you have noted the serial number.</p>
2	<p>Request a Return Materials Authorization (RMA) number from TAC by opening a support case. Open a support case by:</p> <ul style="list-style-type: none"> • Using the Create Service Request form on the iSupport page (see Contacting the Technical Assistance Center). • Contacting Dell Networking directly by E-mail or by phone (see Contacting the Technical Assistance Center). Provide the following information when using E-mail or phone: <ul style="list-style-type: none"> • Part number, description, and serial number of the component. • Your name, organization name, telephone number, fax number, and e-mail address. • Shipping address for the replacement component, including a contact name, phone number, and e-mail address. • A description of the failure, including log messages. This generally includes: <ul style="list-style-type: none"> • the <code>show tech</code> command output • the <code>show trace</code> and <code>show trace hardware</code> command output • for line card issues, the <code>show trace hardware linecard</code> command output • console captures showing any error messages • console captures showing the troubleshooting steps taken • saved messages to a syslog server, if one is used • The support representative will validate your request and issue an RMA number for the return of the component.

Step	Task
3	When returning an RMA component, follow the packing and shipping directions in the Return Instructions document that accompanies the replacement component. Alternatively, contact your TAC representative for a replacement copy. Generally, you are instructed to return the RMA component in the original packaging material provided with the replacement, and to label the package with the RMA number.



Printed in the U.S.A.

www.dell.com | support.dell.com